

Travelling Wave Solutions for Generalized Pochhammer-Chree Equations

Biao Li, Yong Chen, and Hongqing Zhang

Department of Applied Mathematics, Dalian University of Technology,
Dalian 116024, People's Republic of China

Reprint requests to B. Li; E-mail: libiao@student.dlut.edu.cn

Z. Naturforsch. **57 a**, 874–882 (2002); received May 3, 2002

In this paper, by means of a proper transformation and symbolic computation, we study the travelling wave reduction for the generalized Pochhammer-Chree (PC) equations (1.3) and (1.4) by use of the recently proposed extended-tanh method. As a result, rich travelling wave solutions, which include kink-shaped solitons, bell-shaped solitons, periodic solutions, rational solutions, singular solitons, are obtained. At the same time, using a direct assumption method, the more general bell-shaped solitons for the generalized PC Eq. (1.3) are obtained. The properties of the solutions are shown in figures.

Key words: Generalized PC Equations; Extended-tanh Method; Solitons; Symbolic Computation.

1. Introduction

The nonlinear equations of mathematical physics (NEMPS) are major subjects in physical science, and various powerful methods have been presented, such as, the Bäcklund transformation, Darboux transformation, Cole-Hopf transformation, sine-cosine method, Painlevé method, homogeneous balance method, Hirota method, Lie group analysis, similarity reduced method, and so on [1, 2, 7-10]. To obtain new forms of solutions, various ansatz have been proposed. Recently, based on the well-known Riccati equation, Fan presented a useful extended-tanh method [11] to find exact solutions of given NEMPS. More recently, Fan [12, 13] and Yan [14, 15] further developed this idea and made it much more lucid and straightforward for a class of NEMPS. The motivation of this paper is to utilize the extended-tanh method to explore new solutions of the generalized Pochhammer-Chree equations.

The propagation of longitudinal deformation waves in an elastic rod is modelled by the general Pochhammer-Chree (PC) equation

$$u_{tt} - u_{ttxx} - u_{xx} - \frac{1}{p}(u^p)_{xx} = 0, \quad (1.1)$$

where $u(x, t)$ is the longitudinal displacement, at time t , of a material point originally lying at the point x . When $p = 3$ or $p = 5$, (1.1) reflects two possible

constitutive choices of the material [3, 4]. In [3, 4], solitary-wave solutions are obtained when $p = 2$, $p = 3$ and $p = 5$. In [4], the authors presented the more general equation

$$u_{tt} - u_{ttxx} - \sigma(u)_{xx} = 0, \quad (1.2)$$

where σ is a rational function of u .

In this paper, we consider the generalized PC equation

$$u_{tt} - u_{ttxx} - (a_1 u + a_2 u^p + a_3 u^{2p-1})_{xx} = 0, \quad (1.3)$$

where a_1, a_2, a_3 are constants. As dissipation is inevitable in actual problems, we shall further study the more important generalized PC equation

$$u_{tt} - u_{ttxx} + \gamma u_{xxt} - (a_1 u + a_2 u^p + a_3 u^{2p-1})_{xx} = 0, \quad (1.4)$$

where the additional parameters $\gamma \neq 0$ and $a_i (i = 1, 2, 3)$ are constants. The Cauchy problem of the propagation of longitudinal deformation waves in an elastic rod, which includes the dissipate term u_{xxt} , was studied in [5]. In [6], Zhang et al. considered solitary-wave solutions of (1.3) and (1.4) with $p = 2$ and $p = 3$. But to our knowledge, the travelling wave solutions of these two equations have not been studied by now.

This paper is organized as follows: In Sect. 2 we summarize the extended-tanh method. In Sect. 3 we

apply the extended-tanh method to the generalized PC equations (1.3) and (1.4) and obtain many solutions. In section 4 the general bell-shaped solitons of (1.3) are found and six figure characterize some types of the solutions. Conclusions will be presented finally.

2. The Extended-tanh Method

In this section, we describe the extended-tanh method, developed by some authors [11 - 15], for given nonlinear evolution equations in the two variables x, t :

$$F(u, u_t, u_x, u_{xt}, u_{tt}, \dots) = 0. \tag{2.1}$$

Firstly, we make the transformation to a travelling solution

$$u(x, t) = u(\xi), \quad \xi = x - \beta t, \tag{2.2}$$

where β is a constant to be determined later. Then (2.1) reduces to a nonlinear ordinary differential equation (ODE)

$$G(u, u', u'', u''' \dots) = 0, \tag{2.3}$$

which is integrated if all terms contain derivatives, and where “'” denotes $d/d\xi$. The next crucial step is to express the solution of the resulting ODE by the more general ansatz

$$u(\xi) = \sum_{i=1}^m \omega^{i-1}(\xi) [A_i \omega(\xi) + B_i \sqrt{R + \omega^2(\xi)}] + A_0, \tag{2.4}$$

the new variable $\omega = \omega(\xi)$ satisfying

$$\omega' - (R + \omega^2) = \frac{d\omega}{d\xi} - (R + \omega^2) = 0, \tag{2.5}$$

where $A_0, A_i, B_i (i = 1, 2, \dots, m)$ and R are constants to be determined later, and m is a positive integer. However, when we identify the highest order derivative term with the nonlinear term in (2.3), we find that the constant m needs not be restricted to a positive integer. In order to apply the extended-tanh method described in [11 - 15] when m is equal to a fraction or a negative integer, we make the following transformation:

(1) When $m = q/p$ is a low fraction, we substitute

$$u(\xi) = \varphi^{q/p}(\xi) \tag{2.6}$$

into (2.3) and return to determine the value of m by balancing the highest order derivative term with the nonlinear term in the new equation (2.3).

(2) When m is a negative integer, we substitute

$$u(\xi) = \varphi^m(\xi), \tag{2.7}$$

into (2.3) and return to determine the value of m as before.

In general, the constant m can be changed into a positive integer by means of the above transformation. Otherwise, we have to seek another proper transformation.

We summarize the extended-tanh method as follows:

Step 1. Determine the values of m in (2.4) by balancing the highest order derivative term with the nonlinear term in (2.3).

- (i) If m is a positive integer then *Step 2*;
- (ii) If $m = q/p$, we make the transformation (2.6) and then return to *Step 1*;
- (iii) If m is a negative integer, we make the transformation (2.7) and then return to *Step 1*.

Step 2. With the aid of Mathematica, substituting (2.4) along with the condition (2.5) into (2.3) yields a system of algebraic equations with respect to $\omega^k (\sqrt{R + \omega^2})^j (j = 0, 1; k = 0, 1, 2, \dots)$. (where ω^k denotes k power of ω and $(\sqrt{R + \omega^2})^j$ denotes j power of $\sqrt{R + \omega^2}$).

Step 3. Collect all terms with the same power in $\omega^k (\sqrt{R + \omega^2})^j (j = 0, 1; k = 0, 1, 2, \dots)$ and set the coefficients of the terms $\omega^k (\sqrt{R + \omega^2})^j (j = 0, 1; k = 0, 1, 2, \dots)$ to zero to get an over-determined system of nonlinear algebraic equations with respect to the unknown variables $\lambda, R, A_0, A_i, B_i (i = 1, 2, \dots, m)$.

Step 4. With the aid of Mathematica, solving the above over-determined system of nonlinear algebraic equations obtained in *step 3*, yields the values of $\lambda, R, A_0, A_i, B_i (i = 1, 2, \dots, m)$.

Step 5. It is well known that the general solutions of (2.5) are

1. When $R < 0$:

$$\begin{aligned} \omega(\xi) &= -\sqrt{-R} \tanh(\sqrt{-R}\xi), \\ \omega(\xi) &= -\sqrt{-R} \coth(\sqrt{-R}\xi) \end{aligned} \tag{2.8}$$

2. When $R = 0$:

$$\omega(\xi) = -\frac{1}{\xi}, \tag{2.9}$$

3. When $R > 0$:

$$\omega(\xi) = \sqrt{R} \tan(\sqrt{R}\xi), \quad \omega(\xi) = -\sqrt{R} \cot(\sqrt{R}\xi). \tag{2.10}$$

Thus according to (2.2), (2.4), (2.6) or (2.7), (2.8), (2.9), (2.10) and the conclusions in *step 4* we can obtain many travelling wave solutions of (2.1).

3. Travelling Wave Solutions to the Generalized PC Eqs. (1.4) and (1.3)

We now apply the extended-tanh method to the generalized PC equation (1.4). We firstly make the travelling wave transformation

$$u(x, t) = u(\xi), \quad \xi = x - \beta t, \tag{3.1}$$

where β is a constant to be determined.

Substituting (3.1) into (1.4) yields

$$\begin{aligned} &\beta^2 u''(\xi) - \beta^2 u^{(4)}(\xi) - \gamma \beta u'''(\xi) \\ &- [a_1 u(\xi) + a_2 u^p(\xi) + a_3 u^{2p-1}(\xi)]_{\xi\xi} = 0. \end{aligned} \tag{3.2}$$

Integrating the above equation twice, we have

$$\begin{aligned} &\beta^2 u''(\xi) + \gamma \beta u'(\xi) + (a_1 - \beta^2)u(\xi) \\ &+ a_2 u^p(\xi) + a_3 u^{2p-1}(\xi) = 0, \end{aligned} \tag{3.3}$$

with the integration constants taken to be zero.

According to Step 1 in Sect. 2, by balancing the highest order derivative term and the nonlinear term in (3.3), we get $m = 1/(p - 1)$. Therefore we make the transformation

$$u(\xi) = \varphi^{\frac{1}{p-1}}(\xi). \tag{3.4}$$

Then substituting (3.4) into (3.3) yields

$$\begin{aligned} &(p - 1)\beta^2 \varphi(\xi)\varphi''(\xi) + (p - 1)\beta\gamma\varphi(\xi)\varphi'(\xi) \\ &- (p - 2)\beta^2 \varphi'^2(\xi) + (p - 1)^2(a_1 - \beta^2)\varphi^2(\xi) \\ &+ a_2(p - 1)^2 \varphi^3(\xi) + a_3(p - 1)^2 \varphi^4(\xi) = 0. \end{aligned} \tag{3.5}$$

According to Step 1 in Sect. 2, we suppose that (3.5) has the formal solutions

$$\varphi(\xi) = A_0 + A_1 \omega + B_1 \sqrt{R + \omega^2}, \tag{3.6}$$

and $\omega = \omega(\xi)$ satisfies (2.5), where A_0, A_1, B_1 are constants to be determined later.

With the aid of Mathematica, substituting (3.6) into (3.5) along with (2.5) and collecting all terms with the same power in $\omega^k(\sqrt{R + \omega^2})^j$ ($j = 0, 1; k = 0, 1, 2, 3, 4$) yields a system of equations with respect to $\omega^k(\sqrt{R + \omega^2})^j$ ($j = 0, 1; k = 0, 1, 2, 3, 4$) in the obtained system of equations to zero, we deduce the following set of over-determined algebraic polynomials with respect to the unknowns A_0, A_1, B_1, R, β :

$$\begin{aligned} &A_0^3 a_2(-1 + p)^2 + A_0^4 a_3(-1 + p)^2 \\ &+ A_0^2(-1 + p)^2(a_1 + 6a_3 B_1^2 R) \\ &+ R(a_3 B_1^4(-1 + p)^2 R - A_1^2(-2 + p)R\beta^2 \\ &+ B_1^2(-1 + p)(a_1(-1 + p) + R\beta^2)) \\ &+ A_0(-1 + p)R(3a_2 B_1^2(-1 + p) + A_1\beta\gamma) = 0, \end{aligned} \tag{3.7}$$

$$\begin{aligned} &B_1(-1 + p)(3A_0^2 a_2(-1 + p) + 4A_0^3 a_3(-1 + p) \\ &+ A_0(2a_1(-1 + p) + R(4a_3 B_1^2(-1 + p) + \beta^2)) \\ &+ R(a_2 B_1^2(-1 + p) + A_1\beta\gamma)) = 0, \end{aligned} \tag{3.8}$$

$$\begin{aligned} &(-1 + p)(3A_0^2 A_1 a_2(-1 + p) + 4A_0^3 A_1 a_3(-1 + p) \\ &+ 2A_0 A_1(a_1(-1 + p) + R(6a_3 B_1^2(-1 + p) + \beta^2)) \\ &+ R(3A_1 a_2 B_1^2(-1 + p) + A_1^2 \beta\gamma + B_1^2 \beta\gamma)) = 0, \end{aligned} \tag{3.9}$$

$$\begin{aligned} &B_1(2a_1 A_1(-1 + p)^2 + 12A_0^2 A_1 a_3(-1 + p)^2 \\ &+ A_1 R(4a_3 B_1^2(-1 + p)^2 + (1 + p)\beta^2) \\ &+ A_0(-1 + p)(6A_1 a_2(-1 + p) + \beta\gamma)) = 0, \end{aligned} \tag{3.10}$$

$$\begin{aligned} &6A_0^2 a_3(A_1^2 + B_1^2)(-1 + p)^2 \\ &+ A_1^2(a_1(-1 + p)^2 + 2R(3a_3 B_1^2(-1 + p)^2 + \beta^2)) \\ &+ B_1^2(a_1(-1 + p)^2 + R(2a_3 B_1^2(-1 + p)^2 \\ &+ (-1 + 2p)\beta^2)) \end{aligned} \tag{3.11}$$

$$\begin{aligned} &+ A_0(-1 + p)(3A_1^2 a_2(-1 + p) \\ &+ 3a_2 B_1^2(-1 + p) + A_1\beta\gamma) = 0, \end{aligned}$$

$$B_1(-1+p) \left(3A_1^2(a_2+4A_0a_3)(-1+p) + a_2B_1^2(-1+p) + 2A_0(2a_3B_1^2(-1+p) + \beta^2) + 2A_1\beta\gamma \right) = 0, \quad (3.12)$$

$$(-1+p) \left(A_1^3(a_2+4A_0a_3)(-1+p) + A_1[3a_2B_1^2(-1+p) + 2A_0(6a_3B_1^2(-1+p) + \beta^2)] + A_1^2\beta\gamma + B_1^2\beta\gamma \right) = 0, \quad (3.13)$$

$$2A_1B_1(2A_1^2a_3(-1+p)^2 + 2a_3B_1^2(-1+p)^2 + p\beta^2) = 0, \quad (3.14)$$

$$A_1^4a_3(-1+p)^2 + a_3B_1^4(-1+p)^2 + B_1^2p\beta^2 + A_1^2(6a_3B_1^2(-1+p)^2 + p\beta^2) = 0. \quad (3.15)$$

From (3.7) - (3.15), with the aid of *Mathematica*, we have

Case 1.

$$A_0 = \frac{-a_2p \pm \gamma\sqrt{-a_3p}}{2a_3(1+p)},$$

$$A_1 = \pm B_1 = \pm \sqrt{-\frac{p\beta^2}{4a_3(-1+p)^2}}, \quad (3.16)$$

$$R = \frac{4A_0^2a_3(-1+p)^2}{p\beta^2},$$

$$\beta = \pm \sqrt{a_1 + 2a_2A_0 + 4a_3A_0^2}.$$

Case 2.

$$A_0 = \frac{-a_2p \pm \gamma\sqrt{-a_3p}}{2a_3(1+p)},$$

$$A_1 = \pm \sqrt{-\frac{p\beta^2}{a_3(-1+p)^2}}, \quad (3.17)$$

$$R = \frac{A_0^2a_3(-1+p)^2}{p\beta^2},$$

$$\beta = \pm \sqrt{a_1 + 2a_2A_0 + 4a_3A_0^2}.$$

Case 3.

$$R = 0, \quad A_0 = 0,$$

$$A_1 = \pm B_1 = \sqrt{-\frac{a_1p}{16a_3(-1+p)^2}}, \quad (3.18)$$

$$\beta = \pm \sqrt{a_1}, \quad \gamma^2 = -\frac{a_2^2p}{4a_3}.$$

Case 4.

$$\gamma = 0, \quad A_0 = A_1 = a_2 = 0, \quad B_1 = \pm \sqrt{-\frac{p\beta^2}{a_3(-1+p)^2}},$$

$$R = \frac{(-1+p)^2(a_1 - \beta^2)}{\beta^2}. \quad (3.19)$$

Case 5.

$$\gamma = 0, \quad p = 2, \quad A_0 = B_1 = a_2 = 0,$$

$$A_1 = \pm \sqrt{-\frac{2\beta^2}{a_3}}, \quad R = \frac{a_1 - \beta^2}{\beta^2}. \quad (3.20)$$

Case 6.

$$\gamma = 0, \quad A_0 = a_2 = 0, \quad p = 2, \quad (3.21)$$

$$A_1 = \pm B_1 = \pm \sqrt{-\frac{\beta^2}{2a_3}}, \quad R = -\frac{2(a_1 - \beta^2)}{\beta^2}.$$

Case 7.

$$\gamma = A_1 = 0, \quad p = 2, \quad A_0 = -\frac{a_2}{3a_3}, \quad (3.22)$$

$$B_1 = \pm \sqrt{-\frac{2\beta^2}{a_3}}, \quad \beta = \pm \sqrt{a_1 - \frac{2a_2^2}{9a_3}}, \quad R = -\frac{a_2^2}{9a_3\beta^2}.$$

Therefore, combining (2.8), (2.9), (3.1), (3.4), (3.6) along with Cases 1 - 3, the travelling wave solutions of the generalized PC equation (1.4) are found as follows:

Case 1.

When $R < 0$, i. e., $a_3p < 0$:

$$u_{11} = \left\{ A_0[1 \pm \tanh[\sqrt{-R}(x - \beta t + \xi_0)] \pm i \operatorname{sech}[\sqrt{-R}(x - \beta t + \xi_0)]] \right\}^{\frac{1}{p-1}}, \quad (3.23)$$

$$u_{12} = \left\{ A_0[1 \pm \coth[\sqrt{-R}(x - \beta t + \xi_0)] \pm i \operatorname{csch}[\sqrt{-R}(x - \beta t + \xi_0)]] \right\}^{\frac{1}{p-1}}, \quad (3.24)$$

when $R > 0$, i. e., $a_3p > 0$:

$$u_{13} = \left\{ A_0[1 \pm i \tan[\sqrt{R}(x - \beta t + \xi_0)] \pm i \sec[\sqrt{-R}(x - \beta t + \xi_0)]] \right\}^{\frac{1}{p-1}}, \quad (3.25)$$

$$u_{14} = \left\{ A_0 [1 \pm i \cot[\sqrt{-R}(x - \beta t + \xi_0)] \pm i \csc[\sqrt{-R}(x - \beta t + \xi_0)]] \right\}^{\frac{1}{p-1}}, \quad (3.26)$$

where $A_0 = \{ -a_2 p \pm \gamma \sqrt{-a_3 p} \} / 2a_3(1+p)$, $R = 4A_0^2 a_3(-1+p)^2 / p\beta^2$, $\beta = \pm \sqrt{a_1 + 2a_2 A_0 + 4a_3 A_0^2}$ and ξ_0 is an arbitrary constants. (**Note:** the rest of this paper ξ_0 is an arbitrary constants.)

Case 2.

When $R < 0$, i.e., $a_3 p < 0$:

$$u_{21} = \left\{ A_0 [1 \pm \tanh[\sqrt{-R}(x - \beta t + \xi_0)]] \right\}^{\frac{1}{p-1}}, \quad (3.27)$$

$$u_{22} = \left\{ A_0 [1 \pm \coth[\sqrt{-R}(x - \beta t + \xi_0)]] \right\}^{\frac{1}{p-1}}, \quad (3.28)$$

when $R > 0$, $a_3 p > 0$:

$$u_{23} = \left\{ A_0 [1 \pm i \tan[\sqrt{-R}(x - \beta t + \xi_0)]] \right\}^{\frac{1}{p-1}}, \quad (3.29)$$

$$u_{24} = \left\{ A_0 [1 \pm i \cot[\sqrt{-R}(x - \beta t + \xi_0)]] \right\}^{\frac{1}{p-1}}, \quad (3.30)$$

where $A_0 = \{ -a_2 p \pm \gamma \sqrt{-a_3 p} \} / 2a_3(1+p)$, $R = A_0^2 a_3(-1+p)^2 / p\beta^2$, $\beta = \pm \sqrt{a_1 + 2a_2 A_0 + 4a_3 A_0^2}$.

Case 3.

From (3.18), (1.4) has the rational solutions

$$u_3 = \left\{ \pm \sqrt{-\frac{a_1 p}{4a_3(-1+p)^2}} \frac{1}{x \pm \sqrt{a_1} t + \xi_0} \right\}^{\frac{1}{p-1}}, \quad (3.31)$$

where $\gamma^2 = -a_2^2 p / 4a_3$.

The results given in [6] are special cases with $p = 2$ of our solutions (3.27). But, to our knowledge, the other obtained solutions have not been found before.

Next, we shall consider the travelling wave solutions of the generalized PC equation (1.3). From (3.23) - (3.31) under $\gamma = 0$ and (3.19) - (3.20), the following travelling solutions for the generalized PC equation (1.3) are obtained (to simplify, the periodic formal solutions are omitted):

Case 1.

$$u_{11} = \left\{ A [1 \pm \tanh[\sqrt{-R}(x - \beta t + \xi_0)] \pm i \operatorname{sech}[\sqrt{-R}(x - \beta t + \xi_0)]] \right\}^{\frac{1}{p-1}}, \quad (3.32)$$

$$u_{12} = \left\{ A [1 \pm \coth[\sqrt{-R}(x - \beta t + \xi_0)] \pm i \operatorname{csch}[\sqrt{-R}(x - \beta t + \xi_0)]] \right\}^{\frac{1}{p-1}}, \quad (3.33)$$

where $A = -a_2 p / 2a_3(1+p)$, $R = 4A^2 a_3(-1+p)^2 / p\beta^2 < 0$, $\beta = \pm \sqrt{a_1 + 2a_2 A + 4a_3 A^2}$.

Case 2.

$$u_{21} = \left\{ A [1 \pm \tanh[\sqrt{-R}(x - \beta t + \xi_0)]] \right\}^{\frac{1}{p-1}}, \quad (3.34)$$

$$u_{22} = \left\{ A [1 \pm \coth[\sqrt{-R}(x - \beta t + \xi_0)]] \right\}^{\frac{1}{p-1}}, \quad (3.35)$$

where $A = -a_2 p / 2a_3(1+p)$, $R = A^2 a_3(-1+p)^2 / p\beta^2 < 0$, $\beta = \pm \sqrt{a_1 + 2a_2 A + 4a_3 A^2}$.

Case 3.

From (3.31) we can only deduce the rational solutions of the equation $u_{tt} - u_{ttxx} - (a_1 u + a_3 u^{2p-1})_{xx} = 0$ as follows:

$$u_3 = \left\{ \pm \sqrt{-\frac{a_1 p}{4a_3(-1+p)^2}} \frac{1}{x \pm \sqrt{a_1} t + \xi_0} \right\}^{\frac{1}{p-1}}. \quad (3.36)$$

Case 4.

From (3.19), the general PC equation $u_{tt} - u_{ttxx} - (a_1 u + a_3 u^{2p-1})_{xx} = 0$ has the following solutions for $a_1 - \beta^2 < 0$:

$$u_{41} = \left\{ \pm \sqrt{\frac{p(a_1 - \beta^2)}{a_3}} \right\}^{\frac{1}{p-1}}, \quad (3.37)$$

$$\cdot \operatorname{sech} \left[\pm \sqrt{-\frac{(-1+p)^2(a_1 - \beta^2)}{\beta^2}} (x - \beta t + \xi_0) \right] \right\}^{\frac{1}{p-1}},$$

$$u_{42} = \left\{ \pm \sqrt{-\frac{p(a_1 - \beta^2)}{a_3}} \right\}^{\frac{1}{p-1}}, \quad (3.38)$$

$$\cdot \operatorname{csch} \left[\pm \sqrt{-\frac{(-1+p)^2(a_1 - \beta^2)}{\beta^2}} (x - \beta t + \xi_0) \right] \right\}^{\frac{1}{p-1}}.$$

Case 5.

From (3.20), the equation $u_{tt} - u_{ttxx} - (a_1 u + a_3 u^3)_{xx} = 0$ has the following solutions for $a_1 - \beta^2 < 0$:

$$u_{51} = \pm \sqrt{\frac{2(a_1 - \beta^2)}{a_3}} \cdot \tanh \left[\pm \sqrt{-\frac{a_1 - \beta^2}{\beta^2}}(x - \beta t + \xi_0) \right], \quad (3.39)$$

$$u_{52} = \pm \sqrt{\frac{2(a_1 - \beta^2)}{a_3}} \cdot \coth \left[\pm \sqrt{-\frac{a_1 - \beta^2}{\beta^2}}(x - \beta t + \xi_0) \right]. \quad (3.40)$$

Case 6.

From (3.21), the equation $u_{tt} - u_{ttxx} - (a_1u + a_3u^3)_{xx} = 0$ has also the following solutions if $a_1 - \beta^2 < 0$

$$u_{61} = \pm \sqrt{-\frac{a_1 - \beta^2}{a_3}} \cdot \left\{ \tanh \left[\sqrt{\frac{2(a_1 - \beta^2)}{\beta^2}}(x - \beta t + \xi_0) \right] \right. \quad (3.41)$$

$$\left. \pm i \operatorname{sech} \left[\sqrt{\frac{2(a_1 - \beta^2)}{\beta^2}}(x - \beta t + \xi_0) \right] \right\},$$

$$u_{62} = \pm \sqrt{-\frac{a_1 - \beta^2}{a_3}} \cdot \left\{ \coth \left[\sqrt{\frac{2(a_1 - \beta^2)}{\beta^2}}(x - \beta t + \xi_0) \right] \right. \quad (3.42)$$

$$\left. \pm \operatorname{csch} \left[\sqrt{\frac{2(a_1 - \beta^2)}{\beta^2}}(x - \beta t + \xi_0) \right] \right\}.$$

Case 7.

From (3.22), the equation $u_{tt} - u_{ttxx} - (a_1u + a_2u^2 + a_3u^3)_{xx} = 0$ has the following solutions

$$u_{71} = -\frac{a_2}{3a_3} \pm \sqrt{-\frac{2a_2^2}{9a_3^2}} \operatorname{sech} \left[\sqrt{\frac{a_2^2}{9a_3\beta^2}}(x - \beta t + \xi_0) \right], \quad (3.43)$$

$$u_{71} = -\frac{a_2}{3a_3} \pm \sqrt{\frac{2a_2^2}{9a_3^2}} \operatorname{csch} \left[\sqrt{\frac{a_2^2}{9a_3\beta^2}}(x - \beta t + \xi_0) \right], \quad (3.44)$$

where $\beta^2 = a_1 - 2a_2^2/9a_3$, $a_3 > 0$.

The results given in [6] are special cases with $p = 2$ of our solutions (3.27), (3.34) and (3.43). From (3.37), it is not difficult to obtain the solutions of (1.1) as follows:

$$u(x, t) = \left[\pm \sqrt{\frac{(\beta^2 - 1)p(p + 1)}{2}} \cdot \operatorname{sech} \left[\frac{(p - 1)\sqrt{\beta^2 - 1}}{2\beta}(x - \beta t + \xi_0) \right] \right]^{\frac{2}{p-1}}. \quad (3.45)$$

The above solution is just the solution (1.2) in [4]. But, to our knowledge, the other solutions obtained here were not found before.

4. The Bell-shaped Solitons to the Generalized PC Equation (1.3)

In Sect. 3, the bell-shaped soliton (3.37) for the PC equation (1.3) with $a_2 = 0$ are obtained. In this section we consider the bell-shaped solitons for the generalized PC equation (1.3) under the condition $a_2 \neq 0$. Setting $\gamma = 0$ in formula (3.5), it changes into the equation

$$(p - 1)\beta^2\varphi(\xi)\varphi''(\xi) - (p - 2)\beta^2\varphi'^2(\xi) + (p - 1)^2(a_1 - \beta^2)\varphi^2(\xi) + a_2(p - 1)^2\varphi^3(\xi) + a_3(p - 1)^2\varphi^4(\xi) = 0. \quad (4.1)$$

Now, we assume that the solution of (4.1) has the form

$$\varphi(\xi) = \frac{Ae^{\alpha(\xi+\xi_0)}}{(1 + e^{\alpha(\xi+\xi_0)})^2 + Be^{\alpha(\xi+\xi_0)}} = \frac{A \operatorname{sech}^2(\alpha/2)(\xi + \xi_0)}{4 + B \operatorname{sech}^2(\alpha/2)(\xi + \xi_0)}, \quad (4.2)$$

where A, B and α are constants to be determined, and ξ_0 is an arbitrary constant phase shift.

With the aid of Mathematica, substituting (4.2) into (4.1) we obtain

$$A^2(a_1(-1 + p)^2 + (-1 + 2p - p^2 + \alpha^2)\beta^2) = 0, \quad (4.3)$$

$$A^2(-1 + p)(Aa_2(-1 + p) + 2a_1(2 + B)(-1 + p) - (2 + B)(-2 + 2p + \alpha^2)\beta^2) = 0, \quad (4.4)$$

$$A^2 \left(A^2a_3(-1 + p)^2 + Aa_2(2 + B)(-1 + p)^2 + a_1(6 + 4B + B^2)(-1 + p)^2 - (6 + 4B(-1 + p))^2 + B^2(-1 + p)^2 + 6p^2 - 2\alpha^2 + 4p(-3 + \alpha^2) \right) \beta^2 = 0, \quad (4.5)$$

$$A^2(-1+p)(Aa_2(-1+p) + 2a_1(2+B)(-1+p) - (2+B)(-2+2p+\alpha^2)\beta^2) = 0, \quad (4.6)$$

$$A^2(a_1(-1+p)^2 + (-1+2p-p^2+\alpha^2)\beta^2) = 0. \quad (4.7)$$

By solving (4.3) - (4.7) with the aid of *Mathematica*, we get the conclusions

$$\alpha = \pm \frac{(p-1)\sqrt{\beta^2 - a_1}}{\beta}, \quad (4.8)$$

$$A = \pm \frac{2(1+p)(\beta^2 - a_1)\sqrt{p}}{\sqrt{a_2^2 p + a_3(1+p)^2(\beta^2 - a_1)}}, \quad (4.9)$$

$$B = -2 \pm \frac{2a_2\sqrt{p}}{\sqrt{a_2^2 p + a_3(1+p)^2(\beta^2 - a_1)}}. \quad (4.10)$$

Therefore, there are two solutions of the form (4.2) for (4.1):

$$\varphi_1(\xi) = \frac{\frac{(1+p)(\beta^2 - a_1)\sqrt{p}}{\sqrt{a_2^2 p + a_3(1+p)^2(\beta^2 - a_1)}} \operatorname{sech}^2\left[\frac{(p-1)\sqrt{\beta^2 - a_1}}{2|\beta|}(x - \beta t + \xi_0)\right]}{2 + \left(-1 + \frac{2a_2\sqrt{p}}{\sqrt{a_2^2 p + a_3(1+p)^2(\beta^2 - a_1)}}\right) \operatorname{sech}^2\left[\frac{(p-1)\sqrt{\beta^2 - a_1}}{2|\beta|}(x - \beta t + \xi_0)\right]}, \quad (4.11)$$

$$\varphi_2(\xi) = \frac{-\frac{(1+p)(\beta^2 - a_1)\sqrt{p}}{\sqrt{a_2^2 p + a_3(1+p)^2(\beta^2 - a_1)}} \operatorname{sech}^2\left[\frac{(p-1)\sqrt{\beta^2 - a_1}}{2|\beta|}(x - \beta t + \xi_0)\right]}{2 + \left(-1 - \frac{2a_2\sqrt{p}}{\sqrt{a_2^2 p + a_3(1+p)^2(\beta^2 - a_1)}}\right) \operatorname{sech}^2\left[\frac{(p-1)\sqrt{\beta^2 - a_1}}{2|\beta|}(x - \beta t + \xi_0)\right]}. \quad (4.12)$$

From (3.4), (4.11) and (4.12), the generalized PC equation (1.3) has the following solutions

$$u_1(x, t) = u(x - \beta t) = [\varphi_1(\xi)]^{\frac{1}{p-1}}, \quad (4.13)$$

where $\varphi_1(\xi)$ is given by (4.11).

$$u_2(x, t) = u(x - \beta t) = [\varphi_2(\xi)]^{\frac{1}{p-1}}, \quad (4.14)$$

where $\varphi_2(\xi)$ is given by (4.12).

Notice that (1.1) is a special form of (1.3). By use of the formulae (4.13) and (4.14), it is not difficult to obtain the same solution as (3.45). If taking $p = 2, 3$ in (4.13) and (4.14) respectively, the solutions in [6] are recovered. In addition, by means of the transformation

$$u(\xi) = \varphi^{\frac{2}{p-1}}(\xi) \quad (4.15)$$

for the general PC equation (1.1), according to the steps in Sect. 3, we can also obtain the same bell-shaped solitons (3.45) to (1.1).

By use of *Maple*, we complete six figures to display and characterize some types of the solutions.

5. Conclusions

In summary, making use of the extended-tanh method and symbolic computation, we have derived

many types of travelling solutions for the generalized PC equations (1.3) and (1.4) by proper transformations. Secondly, utilizing the direction assumption method, the more general bell-shaped solitons for the PC equation (1.3) are obtained. The method can be used to seek more travelling wave solutions of NEMPS. In addition, this method is also computerizable, which allows us to perform complicated and tedious algebraic calculation on a computer.

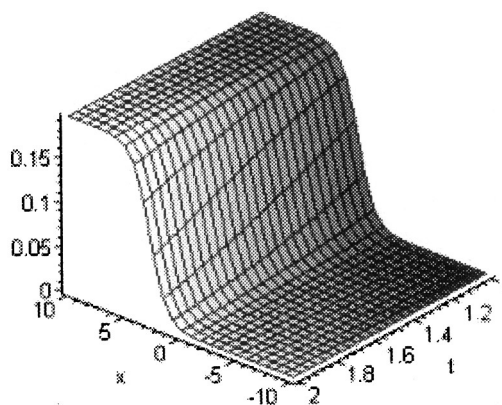

Fig. 1. Real part of solution (3.23) with parameters $A_0 = 1, a_1 = 4, a_2 = 1, a_3 = 1, p = 2, \beta = 2, \gamma = 1$.

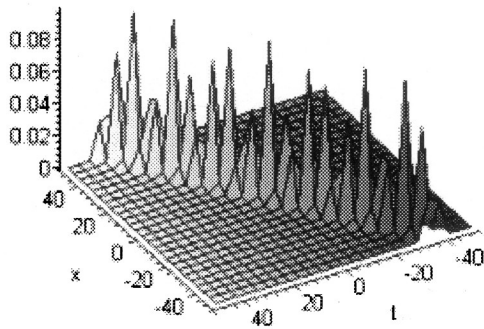

Fig. 2. Imaginary part of solution (3.23) with parameters $A_0 = 1, a_1 = 4, a_2 = 1, a_3 = -1, p = 2, \beta = 2, \gamma = 1$.

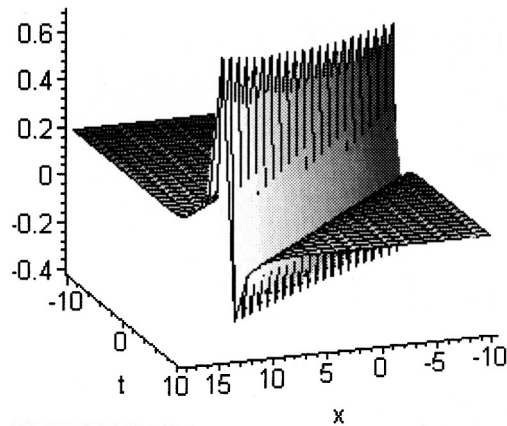

Fig. 4. Solution (3.28) with parameters $A_0 = 1, a_1 = 4, a_2 = 1, a_3 = -1, p = 2, \beta = 2, \gamma = 1$.

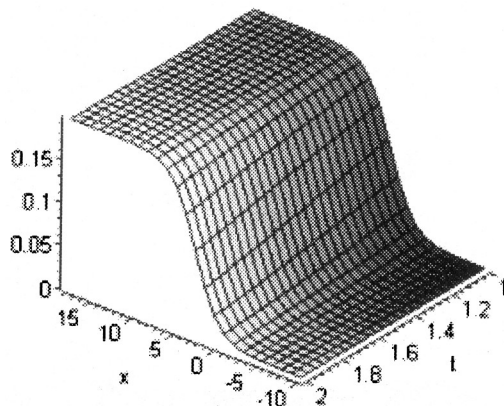

Fig. 3. Solution (3.27) with parameters $A_0 = 1, a_1 = 4, a_2 = 1, a_3 = -1, p = 2, \beta = 2, \gamma = 1$.

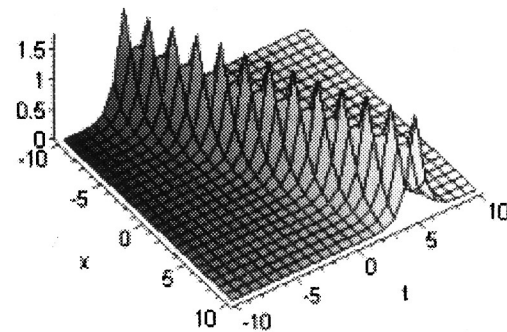

Fig. 5. Solution (3.37) with parameters $a_1 = 1, a_2 = -1, p = 3, \beta = 2$.

Acknowledgements

The work is supported by the National Natural Science Foundation of China under the Grant No. 1007201, the National Key Basic Research Development Project Program under the Grant No. G1998030600.

Appendix

In order to show that the transformation (2.7) is correct for some PDEs, we consider the nonlinear heat conduction equation [11,16]

$$u_t - (u^2)_{xx} = pu - qu^2, \tag{A1}$$

where $p, q \neq 0$ are constants.

Let $u(x, t) = u(\xi), \xi = x - \lambda t$, then (A1) reduces to

$$-\lambda u' - (u^2)'' - pu + qu^2 = 0. \tag{A2}$$

Balancing between u' and $(u^2)''$ yields $m = -1$, which is a negative integer. Let $u(\xi) = v(\xi)^{-1}$, then (A2) becomes

$$-pv^3 - 6v'^2 + v^2(q + \lambda v') + 2vv'' = 0, \tag{A3}$$

Now balancing v^2v' with vv'' , we obtain $m = 1$. Therefore we assume that

$$v = A_0 + A_1\omega + B_1\sqrt{R + \omega^2} \tag{A4}$$

and ω satisfies (2.5).

Substituting (A4) into (A3) yields

$$\begin{aligned} -A_0^3p - 3A_0B_1^2pR + A_0^2(q + A_1R\lambda) \\ + R(-6A_1^2R + B_1^2(q + 2R + A_1R\lambda)) = 0, \\ B_1(-3A_0^2p - B_1^2pR + 2A_0(q + R + A_1R\lambda)) = 0, \\ -3A_0^2A_1p - 3A_1B_1^2pR + 2A_0(A_1(q + 2R) \\ + A_1^2R\lambda + B_1^2R\lambda) = 0, \end{aligned}$$

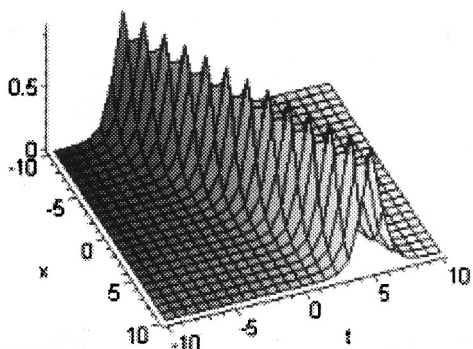

Fig. 6. Solution (4.13) with parameters $a_1 = 1$, $a_2 = 6$, $a_3 = -1$, $p = 4$, $\beta = 2$.

$$\begin{aligned} B_1(-6A_0A_1p + 2A_1(q - 3R) + A_0^2\lambda \\ + 2A_1^2R\lambda + B_1^2R\lambda) &= 0, \\ -3A_0(A_1^2 + B_1^2)p + B_1^2q + A_1^2(q - 8R) + A_0^2A_1\lambda \\ + A_1^3R\lambda + 4A_1B_1^2R\lambda &= 0, \\ B_1(-(3A_1^2 + B_1^2)p + 4A_0(1 + A_1\lambda)) &= 0, \\ -A_1(A_1^2 + 3B_1^2)p + 2A_0(2A_1 + A_1^2\lambda + B_1^2\lambda) &= 0, \\ B_1(-4A_1 + 3A_1^2\lambda + B_1^2\lambda) &= 0, \\ -2A_1^2 - 2B_1^2 + A_1^3\lambda + 3A_1B_1^2\lambda &= 0. \end{aligned}$$

The above equations have two solutions

$$\begin{aligned} A_0 = \frac{q}{2p}, \quad A_1 = \pm \frac{2\sqrt{q}}{p}, \quad B_1 = 0, \\ R = -\frac{q}{16}, \quad \lambda = \pm \frac{p}{\sqrt{q}}, \end{aligned} \quad (\text{A5})$$

$$\begin{aligned} A_0 = \frac{q}{2p}, \quad A_1 = \pm B_1 = \pm \frac{\sqrt{q}}{p}, \\ R = -\frac{q}{4}, \quad \lambda = \pm \frac{p}{\sqrt{q}}. \end{aligned} \quad (\text{A6})$$

Therefore we have,

$$u_{11} = \left\{ \frac{q}{2p} \left[1 \pm \tanh \left[\frac{\sqrt{q}}{4} \left(x \pm \frac{p}{\sqrt{q}} \right) \right] \right] \right\}^{-1},$$

$$u_{12} = \left\{ \frac{q}{2p} \left[1 \pm \coth \left[\frac{\sqrt{q}}{4} \left(x \pm \frac{p}{\sqrt{q}} \right) \right] \right] \right\}^{-1}.$$

$$\begin{aligned} u_{21} = \left\{ \frac{q}{2p} \left[1 \pm \tanh \left[\frac{\sqrt{q}}{2} \left(x \pm \frac{p}{\sqrt{q}} \right) \right] \right] \right. \\ \left. \pm i \operatorname{sech} \left[\frac{\sqrt{q}}{2} \left(x \pm \frac{p}{\sqrt{q}} \right) \right] \right\}^{-1}, \end{aligned}$$

$$\begin{aligned} u_{22} = \left\{ \frac{q}{2p} \left[1 \pm \coth \left[\frac{\sqrt{q}}{2} \left(x \pm \frac{p}{\sqrt{q}} \right) \right] \right] \right. \\ \left. \pm \operatorname{csch} \left[\frac{\sqrt{q}}{2} \left(x \pm \frac{p}{\sqrt{q}} \right) \right] \right\}^{-1}. \end{aligned}$$

- [1] M. J. Ablowitz and P. A. Clarkson, *Soliton, Nonlinear Evolution Equations, and Inverse Scattering*, Cambridge U. P., New York 1991.
- [2] Gu C. H. et al., *Soliton Theory and its Application*, Zhejiang Science and Technology Press, Zhejiang 1990 (in Chinese).
- [3] I. L. Bogolubsky, *Comput. Phys. Commun.* **13**, 149 (1977).
- [4] P. A. Clarkson, R. J. LeVeque, and R. Saxton, *Stud. in Appl. Math.* **75**, 95(1986).
- [5] R. Saxton, *J. Math. Anal. Appl.* **105**, **59** (1985).
- [6] W. G. Zhang and W. X. Ma, *Appl. Math. Mech.* **20**, 625 (1999) (in Chinese).
- [7] M.L. Wang, *Phys. Lett. A* **213**, 279(1996).
- [8] M.L. Wang, Y. B. Zhou, and Z. B. Li, *Phys. Lett. A* **216**, 67 (1996).
- [9] E. Fan and H. Q. Zhang, *Phys. Lett. A* **245**, 389 (1998).
- [10] E. Fan and H. Q. Zhang, *Phys. Lett. A* **246**, 403 (1998).
- [11] E. Fan, *Phys. Lett. A* **277**, 212 (2000).
- [12] E. Fan, *Z. Naturforsch.* **56a**, 312 (2001).
- [13] E. Fan, J. Zhang and Benny Y. C. Hon, *Phys. Lett. A* **291**, 376 (2001).
- [14] Z. Y. Yan, *Z. Naturforsch.* **56a**, 809 (2001).
- [15] Z. Y. Yan, *Phys. Lett. A* **292**, 100 (2001).
- [16] H. Whitemsson, *Phys. Rev. A* **36**, 965 (1990).